



SYSTÈMES DE GESTION DU CARBURANT



DISTRIBUTEURS



KITS



POMPES



COMPTEURS



PISTOLETS

# PANTHER AC

## CARACTÉRISTIQUES

- CONCEPTION COMPACTE ET SOLIDE
- PRÊT À L'USAGE
- FACILE À INSTALLER
- FILTRE INTÉGRÉ

PANTHER AC de PIUSI est une pompe de transvasement rotative électrique à aubes polyvalente et à amorçage automatique disponible en trois versions (56 - 72 - 90) particulièrement adaptée aux distributeurs, systèmes de transvasement de carburant fixes et autres applications industrielles. Elle est équipée d'une vanne de dérivation et d'un filtre pour bloquer les impuretés.

### PERFORMANCES

JUSQU'À  
**90 L/MIN**

DÉBIT

**AC**

TENSION



PANTHER 56 (bride non inclus)



PANTHER 72 - PANTHER 90 (bride inclus)



### PACKAGING

CODE	POIDS		PACKAGING			N. BOX / EUROPALLET	
	KG	LBS	MM	INCH	PCS/BOÎTE	✈	🚚
<b>PANTHER 56</b>							
FO0730000	7,4	16,3	345X175X255	-	1	60	84
000731000	7,4	16,3	345X175X255	-	1	60	84
000733000	7,4	16,3	345X175X255	-	1	60	84
<b>PANTHER 72</b>							
000732000	7,9	17,4	345X175X255	-	1	60	84
000735000	7,9	17,4	345X175X255	-	1	60	84
<b>PANTHER 90</b>							
FO0733020	9,007	19,9	345X175X255	-	1	60	84



FILTRAGE



SURVEILLANCE DES LIQUIDES



ENROULEUR



ACCESSOIRES



MERCHANDISE

INDEX



AIR



ANTIGEL



AdBlue®



BIODIESEL



DIESEL



ALIMENTATION



ESSENCE



GRAISSE



KÉROSÈNE



HUILE



EAU



LAVE-GLACE

## GRAPHIQUE

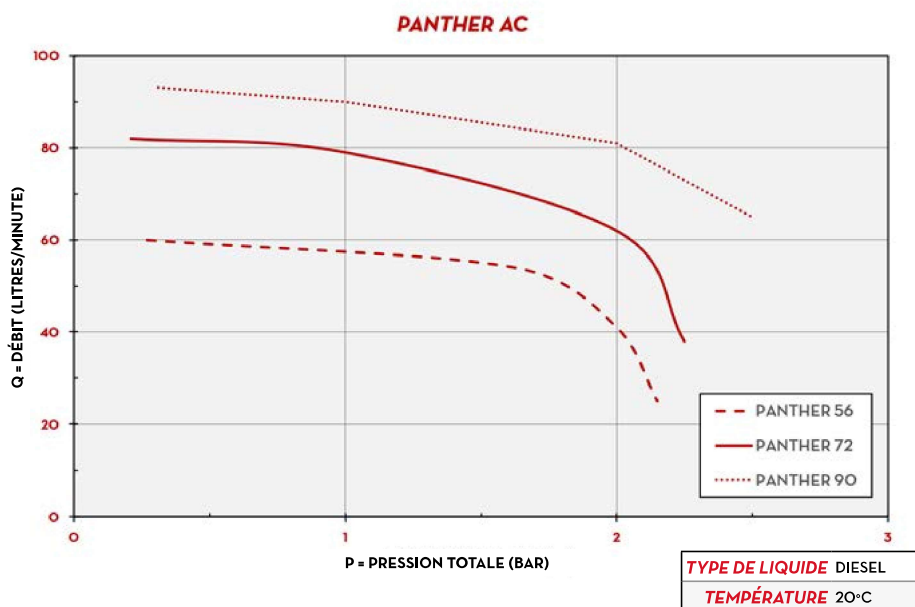

## CONTENU DE L'EMBALLAGE

- POMPE PANTHER AC
- MANUEL D'INSTRUCTIONS

## DÉTAILS



## DIMENSIONS

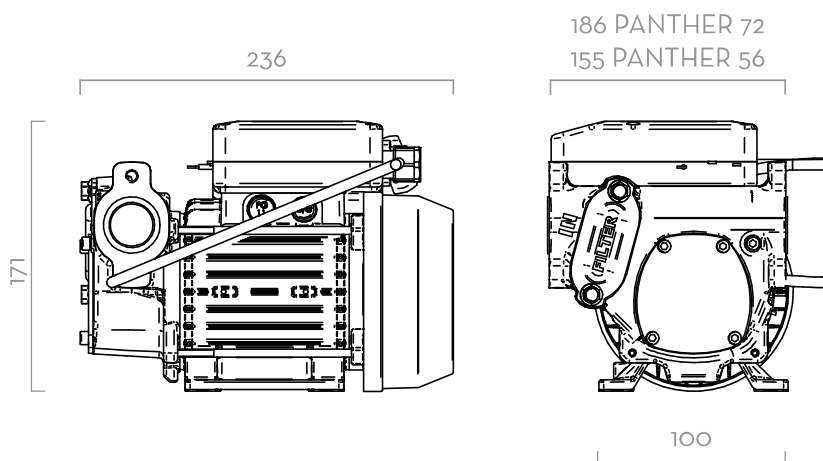

Dimensions exprimées en millimètres

## MATÉRIAUX

- CORPS: FONTE
- ROTOR: ACIER FRITTÉ
- AUBES: TECHNOLYMER
- ARBRE: ACIER



POMPE



RÉSERVOIR

- > MAX. 6 M (20 FT),
- > TUYAU D'ASPIRATION Ø 1" MÍN,
- > HAUTEUR D'ASPIRATION MAX:
  - 2M (7FT) SANS CLAPET ANTI-RETOUR
  - 4M (14FT) AVEC CLAPET ANTI-RETOUR

## DONNÉES TECHNIQUES

CODE	DESCRIPTION	TYPE DE LIQUIDES	DÉBIT		TENSION				RPM	ENTRÉE/SORTIE BSP	JOINT À BRIDE	VANNE DE DÉRIVATION	FILTRE D'ENTRÉE	DUTY CYCLE MINUTE
			L/MIN	GPM	MOTEUR MONOPHASE V/Hz	MOTEUR TRIPHASE V/Hz	PUISANCE WATT	AMP. MAX.						
<b>PANTHER 56</b>														
FO0730000	PANTHER 56 230/50	D	56	15	230/50	-	350	3	2900	1"	-	OUI	OUI	
000731000	PANTHER 56 230/60	D	70	18	230/60	-	500	3,9	3400	1"	-	OUI	OUI	
000733000	PANTHER 56 400/50	D	56	15	-	400/50	500	1,3	2900	1"	-	OUI	OUI	
<b>PANTHER 72</b>														
000732000	PANTHER 72 230/50	D	72	19	230/50	-	500	4,2	2900	1"	OUI	OUI	OUI	
000735000	PANTHER 72 400/50	D	72	19	-	400/50	500	1,6	2900	1"	OUI	OUI	OUI	
<b>PANTHER 90</b>														
FO073302A	PANTHER 90 230/50	D	90	23,8	230/50	-	700	4,9	2900	1"	OUI	OUI	OUI	30

SUR DEMANDE, PRODUIT DISPONIBLE AVEC PLUSIEURS TENSIONS ET FRÉQUENCE DE 60 HZ. (\*) SAUF PANTHER 90

# PANTHER AC